



Cover 1:  
Turino Mushroom

Optional Extra  
Scatter Cushions

Optional Extra  
Scatter Cushions

Cover 1:  
Turino Green

Walnut Feet

Cover 1:  
Turino Green

# Ren Leather Collection

Colours represented are to be used as a guide only.  
Please refer to manufacturers swatch for a more accurate colour match.

Please note that leather colour shadings can vary slightly from batch to batch.  
We cannot guarantee a precise match to these samples or between cut lengths and upholstered goods.

foamflex™  
Award Winning Seating Technology

01/02/2024

# REN LEATHER COVER GUIDE: STANDARD BACK ONLY

Please use this guide when ordering the following pieces to clarify cover options.

3 Seater Sofa (3ST)

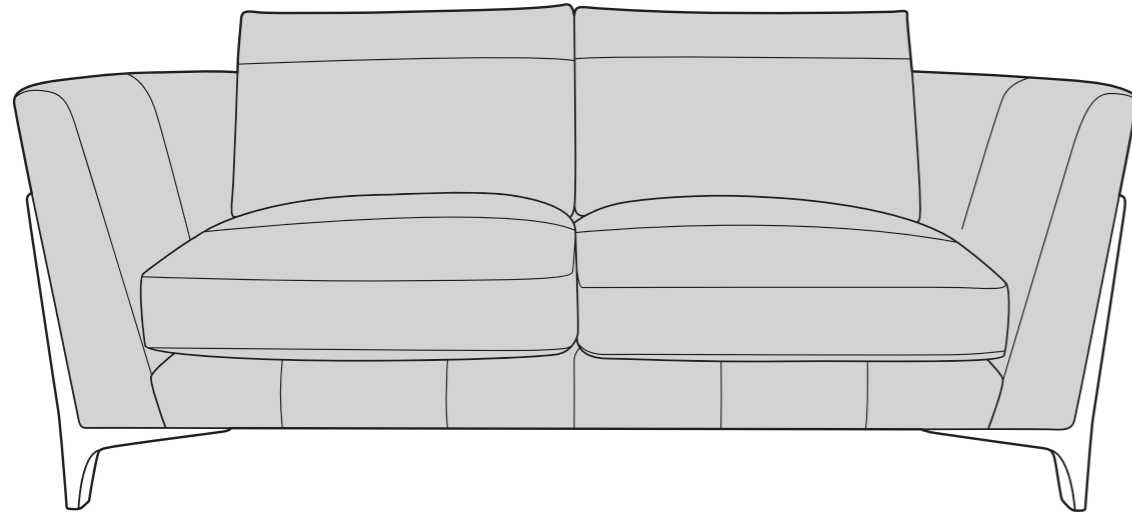

2 Seater Sofa (2ST)

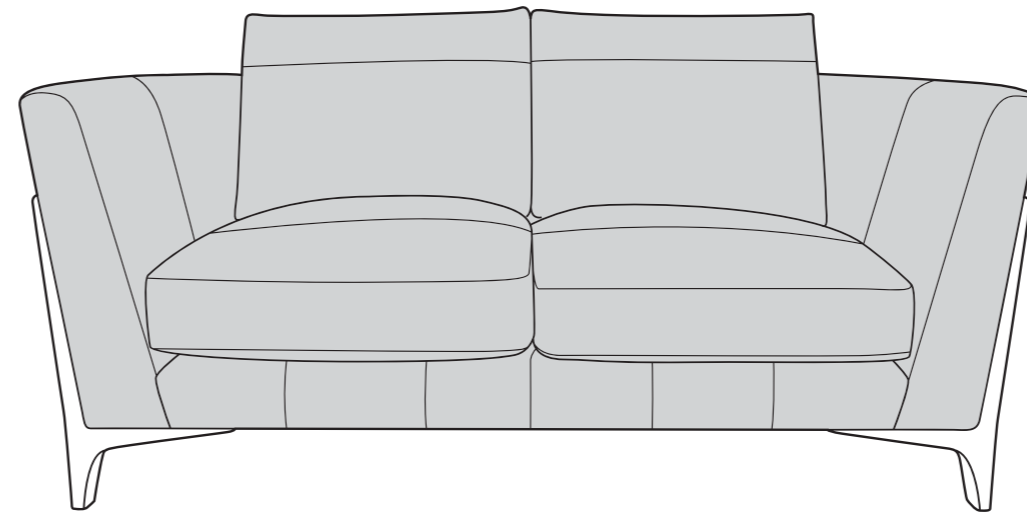

Arm Chair (1ST)

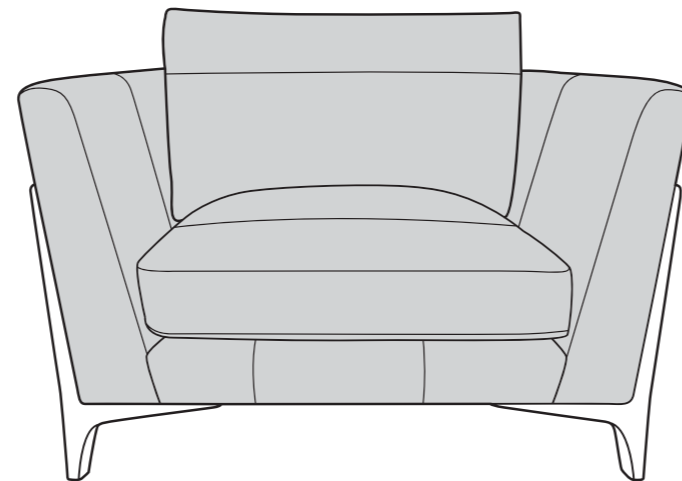

## SUGGESTED ACCENT PIECES

Ren Leather Footstool (FST)

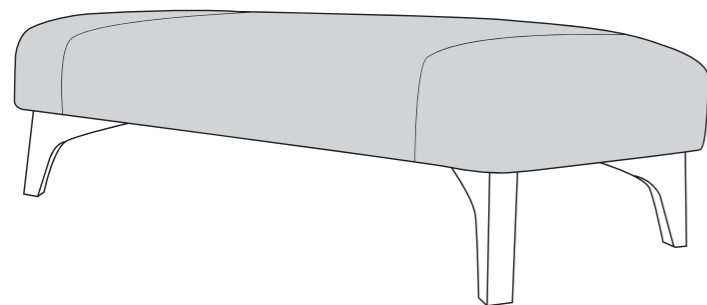

Leather Storage Footstool (FSS)

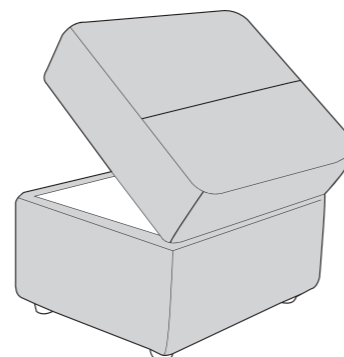



# REN LEATHER DIMENSIONS (CM)

AVAILABLE PIECES	HEIGHT 1	WIDTH 2	DEPTH 3	SEAT HEIGHT 4	SEAT DEPTH (STD) 5	SEAT WIDTH 6	ACCESS DIAGONAL 7	OUTBACK HEIGHT 8	ARM HEIGHT 9	WEIGHT (KG)
3 SEATER SOFA (3ST)	92	196	102	52	62	162	217	79	79	69.5
2 SEATER SOFA (2ST)	92	172	102	52	62	139	198	79	79	58.5
ARM CHAIR (1ST)	92	110	102	52	62	76	146	79	79	47.5
<b>ACCENT PIECES</b>										
REN LEATHER FOOTSTOOL (FST)	30	102	62	N/A	N/A	N/A	117	N/A	N/A	15.5
LEATHER STORAGE FOOTSTOOL (FSS)	45	63	50	N/A	N/A	N/A	75	N/A	N/A	12.5

- \* Hardwood & composite board frame.
- \* Dowelled, screwed, glued & stapled joinery.
- \* Black, Walnut, Mid Oak & Grey Ash Wood foot options.

- \* Award winning foamflex seat interior.
- \* Fibre filled backs for added comfort.
- \* Back Cushions secured with zips.

- \* Serpentine seat springs & silent wire.
- \* Elasticated back webbing

## DIMENSION GUIDE

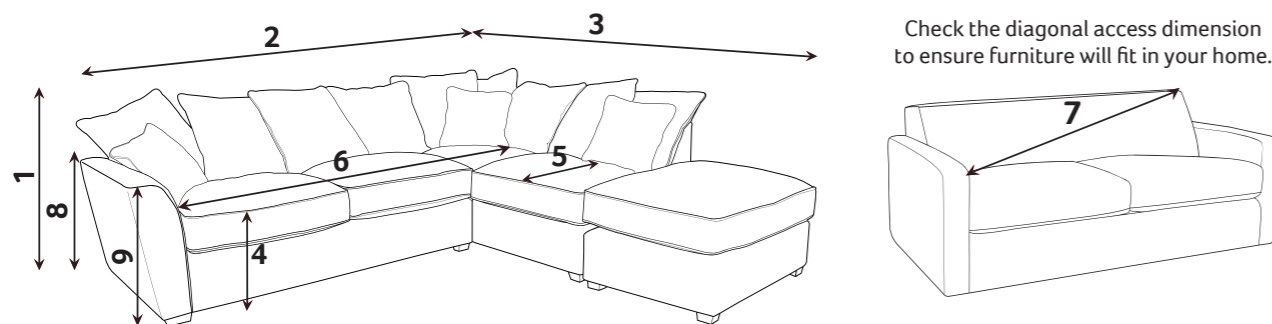

- 1 - HEIGHT
- 2 - WIDTH
- 3 - DEPTH
- 4 - SEAT HEIGHT
- 5 - SEAT DEPTH (STD & PILLOW)
- 6 - SEAT WIDTH
- 7 - DIAGONAL ACCESS
- 8 - OUTBACK HEIGHT
- 9 - ARM HEIGHT

Illustrations used for reference only.

## THIS COLLECTION USES:



Kind Leather focus on creating truly sustainable leather, cutting down on wasted product and the use of harmful chemicals that can be damaging to the environment.

Some of the benefits of Kind Leather include:

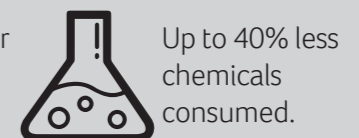
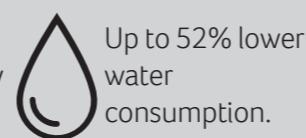
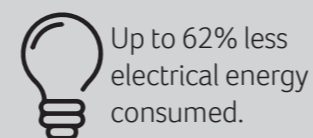

## foamflex™

Our expertly engineered foam seat interior gives you the comfort of fibre with the retention of foam.

## CARE GUIDE

To improve the longevity of your hand-made furniture, we recommend rotating cushions (where applicable).

For further information on maintaining your furniture, please refer to the Care Guide located under the seat platform.

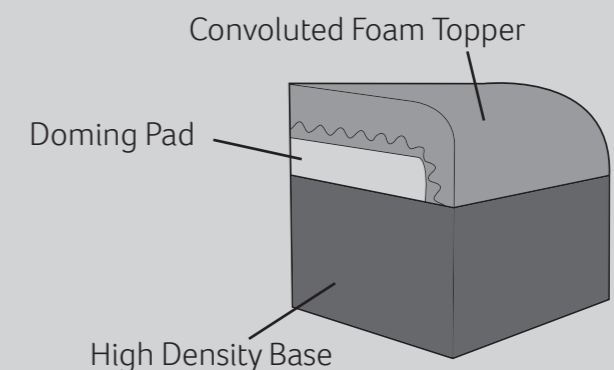

## FOOT OPTIONS:

Black



Walnut



Mid Oak



Grey Ash



Wood is a natural product and will vary in shade/colour from item to item. Foot fitting required.

Please note : All dimension are approximate. Allow tolerance of +/- 2.5cm.



Our foamflex seat interiors have been granted the FIRA GOLD Award, a mark of quality under-pinning all necessary testing of the product materials, design and production techniques.



# LEATHER RANGE

We only use full leather for our collections; no splits apply.



## VERONA

Verona is a Pigmented leather made of top quality heavy-weight hides processed in Italy. The higher-thickness enhances the hand-feel and the visual opulence of the leather. Hides are machine-buffed to remove superficial characteristics before being coated with a pigment to ensure colour consistency. Following this, hides are embossed with an artificial grain to give a uniform appearance and further reduce any visible traces of natural markings. These additional treatments only increase the product's physical durability, reduce absorption from spills, and is a family-friendly option for those seeking to get the most out of leather's hard-wearing properties.



## NAPOLI

Napoli is a natural grain, Semi-Aniline leather made of high quality hides that have been processed in Italy. A special re-tanning process is applied to give the leather its rich hand feel. A contrasting roller effect has been applied to the surface of each hide to add visual character, before being treated with a protective finish to increase durability. A characterful and family-friendly leather.



## TURINO

Turino is lightly-buffed, two-tone natural grain Semi-Aniline leather made of top quality hides that have been processed in Italy. Hides are then finished with a pigment to increase top-coat durability, before a very subtle darker contrasting effect is applied to the tips of the grain to create a discreet two-tone affect. A family friendly leather with a wide appeal.



## CAPRI

Capri is a hand-buffed Aniline leather made of top-quality hides that have been processed in Italy. This leather is a celebration of the rich history of each and every hide and the individual characteristics that make them unique. The hides are buffed by hand, piece by piece. Other than a light protective finish that has been applied to the grain in order to increase its physical performance, Capri's surface is completely natural and free from additional treatments so as to retain the natural look of the leather. Natural leather will be subject to shade variation between and even within upholstered panels, ensuring every piece of furniture is unique.



## LAZIO

Lazio is a naturally rich Aniline leather, crafted from the highest quality hides meticulously processed in Italy. Each hide is given a unique finish of oils and waxes, enhancing the depth and lustre of the colour while offering added protection. This process results in an intriguing 'pull-up' effect, where the colour subtly lightens when stretched or pulled, adding an engaging dynamic element to its character. Lazio elegantly turns the marks of everyday use into an enhancing patina, contributing to its durability and captivating appeal. Natural markings and shade variations may be visible with this leather, highlighting the authenticity of this elegant material, a testament to the charm of natural imperfections.

